**Wireline diamond core drilling equipment —
System A —**

**Part 1:
Metric units**

*Équipement de forage au diamant à ligne à câble avec carottage —
Système A —*

Partie 1: Unités métriques



Contents

1 Scope 1

2 Normative reference 1

3 Designation 1

4 Materials 2

5 Dimensions and tolerances 2

5.1 General 2

5.2 Conformity 2

5.3 Eccentricity 2

5.4 Straightness 2

5.5 Technical conditions 2

Annex A (informative) Principal dimensions of drill rod threads 12

STANDARDSISO.COM : Click to view the full PDF of ISO 10097-1:1999

© ISO 1999

All rights reserved. Unless otherwise specified, no part of this publication may be reproduced or utilized in any form or by any means, electronic or mechanical, including photocopying and microfilm, without permission in writing from the publisher.

International Organization for Standardization
Case postale 56 • CH-1211 Genève 20 • Switzerland
Internet iso@iso.ch

Printed in Switzerland

Foreword

ISO (the International Organization for Standardization) is a worldwide federation of national standards bodies (ISO member bodies). The work of preparing International Standards is normally carried out through ISO technical committees. Each member body interested in a subject for which a technical committee has been established has the right to be represented on that committee. International organizations, governmental and non-governmental, in liaison with ISO, also take part in the work. ISO collaborates closely with the International Electrotechnical Commission (IEC) on all matters of electrotechnical standardization.

International Standards are drafted in accordance with the rules given in the ISO/IEC Directives, Part 3.

Draft International Standards adopted by the technical committees are circulated to the member bodies for voting. Publication as an International Standard requires approval by at least 75 % of the member bodies casting a vote.

International Standard ISO 10097-1 was prepared by Technical Committee ISO/TC 82, *Mining*, Subcommittee SC 6, *Diamond core drilling equipment*.

ISO 10097 consists of the following parts, under the general title *Wireline diamond core drilling equipment — System A*:

- *Part 1: Metric units*
- *Part 2: Inch units*

Annex A of this part of ISO 10097 is for information only.

STANDARDSISO.COM : Click to view the full PDF of ISO 10097-1:1999

Introduction

ISO 10097 is intended for independent use as well as for use in combination with ISO 3551-1, which covers equipment designed for conventional diamond drilling.

This International Standard covers equipment intended for application with diamond bits, but it should be understood that bits may have other cutting materials.

STANDARDSISO.COM : Click to view the full PDF of ISO 10097-1:1999

Wireline diamond core drilling equipment — System A —

Part 1: Metric units

1 Scope

This part of ISO 10097 specifies the nomenclature and the leading dimensions necessary for the interchangeability of the following wireline drilling equipment for drilling holes 48 mm to 96 mm in diameter, yielding cores of 27 mm to 63 mm in diameter.

The equipment is illustrated in Figure 1 and comprises the following:

- a) core bit;
- b) reaming shell;
- c) core lifter;
- d) core lifter case;
- e) outer tube;
- f) inner tube;
- g) drill rod (smooth pipe only).

2 Normative reference

The following normative document contains provisions which, through reference in this text, constitute provisions of this part of ISO 10097. For dated references, subsequent amendments to, or revisions of, this publication do not apply. However, parties to agreements based on this part of ISO 10097 are encouraged to investigate the possibility of applying the most recent edition of the normative document indicated below. For undated references, the latest edition of the normative document referred to applies. Members of ISO and IEC maintain registers of currently valid International Standards.

ISO 3551-1:1992, *Rotary core diamond drilling equipment — System A — Part 1: Metric units*.

3 Designation

Items made in accordance with this part of ISO 10097 shall be designated by the identification letters WL and hole dimensions *A*, *B*, *N*, *H*.

EXAMPLE

Core bit for wireline drilling hole *B* dimensions: WLB core bit.

4 Materials

Materials used in the manufacture of the wireline drilling equipment specified in this part of ISO 10097 shall have the minimum mechanical properties as specified in Table 1.

Table 1 — Mechanical properties

Component	Minimum tensile strength, R_m N/mm ² (MPa)	Minimum yield stress, R_e N/mm ² (MPa)	Minimum elongation after fracture, A %
Drill rods	690	550	12
Core tubes	690	550	12
Other items	Not specified		

5 Dimensions and tolerances

5.1 General

All dimensions and tolerances are in millimetres unless otherwise stated and shall be in accordance with Tables 3 to 9 inclusive.

5.2 Conformity

In those industries where drilling depths are measured in metres, the rod lengths shall be 3 m, 1,5 m or 0,75 m. But when drilling in conformity with DCDMA and CDDA standards, the lengths of rods may be 3,048 m, 1,524 m or 0,762 m.

5.3 Eccentricity

The eccentricity is defined as the distance between the centres of the outer and inner diameters and may not exceed 10 % of nominal wall thickness Q .

The eccentricity is calculated according to the formula:

$$\frac{Q_{\max} - Q_{\min}}{2Q_{\text{nom}}} \times 100$$

where Q_{\max} and Q_{\min} are measured values in the same section.

5.4 Straightness

When measured over the whole length of the tube by rolling against a straightedge, the maximum deviation shall not be greater than:

- for drill rods 1 in 2 000;
- for core tubes 1 in 1 500.

5.5 Technical conditions

Tubes should be made seamless. Tube rolling technique and machining operations are optional.

Tube straightness is checked by rolling the tube on a horizontal or slightly inclined flat surface. When rolling, no clearances shall be seen between the rod ends and the surface, nor between the middle of the rod (tube) and the surface.

Hole drilling by wireline system A equipment shall be cased by system A casing as specified in ISO 3551-1.

Table 2 — System of dimensional identification letters

<i>A, A₁, etc.</i>	Outside diameters; <i>A</i> being largest; <i>A₁, A₂, etc.</i> progressively smaller
<i>B, B₁, etc.</i>	Inside diameters; <i>B</i> being smallest; <i>B₁, B₂, etc.</i> progressively larger
<i>C, C₁, etc.</i>	External lengths; <i>C</i> being longest; <i>C₁, C₂, etc.</i> progressively shorter
<i>D, D₁, etc.</i>	Internal lengths; <i>D</i> being longest; <i>D₁, D₂, etc.</i> progressively shorter
<i>E, E₁, etc.</i>	Major diameter of pin threads; <i>E</i> being largest; <i>E₁, E₂, etc.</i> smaller
<i>F, F₁, etc.</i>	Minor diameter of pin threads; <i>F</i> being largest; <i>F₁, F₂, etc.</i> smaller
Thread pitch (threads per inch)	Pin threads
<i>G, G₁, etc.</i>	Width at root of pin thread
<i>H, H₁, etc.</i>	Length of o.d. machined for external threading
<i>J, J₁, etc.</i>	Minimum length for full depth of pin threads
<i>K, K₁, etc.</i>	Length of relief at the starting point of pin threads
<i>L, L₁, etc.</i>	Angle of bevel for pin thread shoulder
<i>M, M₁, etc.</i>	Major diameter of box threads; <i>M</i> being largest; <i>M₁, M₂, etc.</i> smaller
<i>N, N₁, etc.</i>	Minor diameter of box; <i>N</i> being largest; <i>N₁, N₂, etc.</i> smaller
Thread pitch (threads per inch)	Box threads
<i>P, P₁, etc.</i>	Width at root of box threads
<i>Q, Q₁, etc.</i>	Length of i.d. machined for internal threading
<i>R, R₁, etc.</i>	Minimum length for full depth of box threads
<i>S, S₁, etc.</i>	Length of counter bore at the starting of box threads
<i>T, T₁, etc.</i>	Angle of bevel for thread shoulder
<i>U, U₁, etc.</i>	Included angles: Internal and external
<i>V, V₁, etc.</i>	Internal angles, not pertaining to threaded connections
<i>W, W₁, etc.</i>	External angles, not pertaining to threaded connections
<i>X</i>	Diamond set dimensions: External (o.d.)
<i>Y</i>	Diamond set dimensions: Internal (i.d.)
NOTE 1 All decimal dimensions indicate allowable tolerances.	
NOTE 2 The following common abbreviations have sometimes been used in tables in the English version for the sake of simplicity: o.d = outside diameter i.d. = inside diameter.	

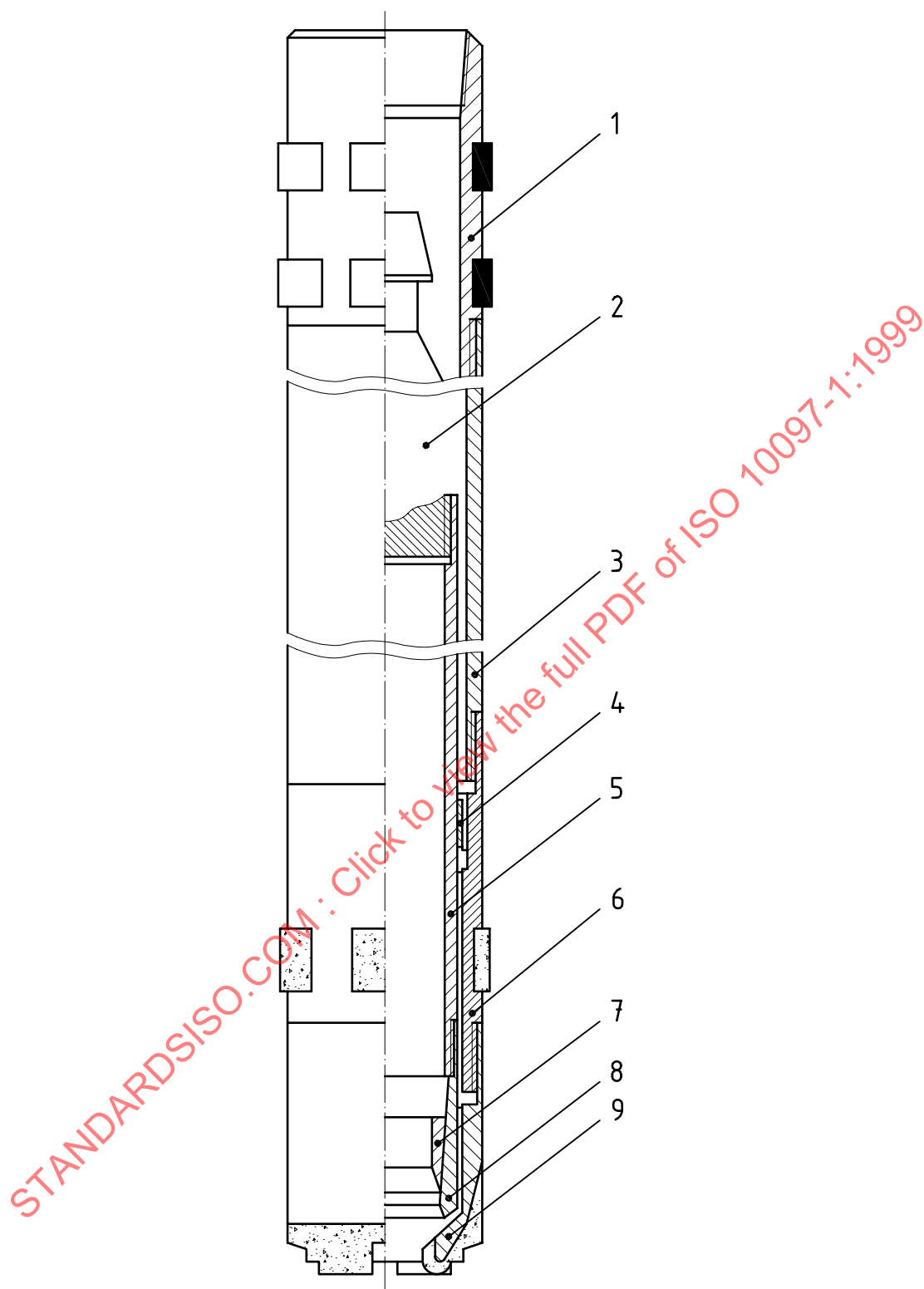

Key

- | | | | |
|---|---------------------------------|---|------------------|
| 1 | Head (not standardized) | 6 | Reaming shell |
| 2 | Bearing unit (not standardized) | 7 | Core lifter |
| 3 | Outer core barrel | 8 | Core lifter case |
| 4 | Stabilizer (not standardized) | 9 | Bit |
| 5 | Retractable core barrel | | |

Figure 1 — Wireline core barrel assembly

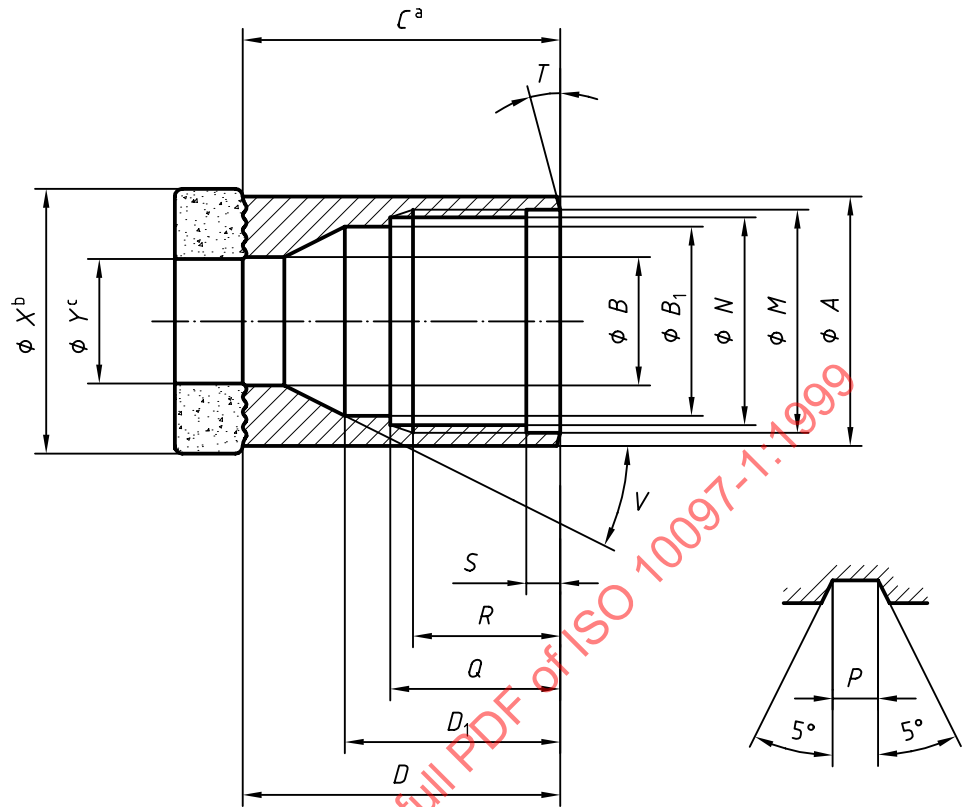

- a Clear of diamonds
- b Set o.d.
- c Set i.d.

Figure 2 — Wireline core bit

Table 3 — Wireline core bit (see Figure 2)

Dimension		WLA	WLB	WLN	WLH
A	max.	46,66	57,96	73,91	94,31
	min.	46,56	57,86	73,81	94,21
B	max.	27,89	37,70	48,82	64,69
	min.	27,76	36,91	48,02	63,90
B_1	max.	36,91	46,43	60,72	78,18
	min.	36,12	45,64	59,93	77,39
C	min.	57,91	66,04	65,41	96,22
D	max.	58,71	66,83	66,20	97,01
	min.	57,91	66,04	65,41	96,22
D_1	max.	49,61	57,55	54,37	83,74
	min.	48,82	56,75	53,58	82,95
M	max.	42,09	52,43	67,51	85,78
	min.	42,04	52,37	67,46	85,70
N	max.	40,59	50,85	65,99	84,20
	min.	40,51	50,80	65,94	84,12
Thread pitch		6,35	6,35	6,35	6,35
P	max.	3,20	3,20	3,20	3,20
	min.	3,12	3,12	3,12	3,12
Q	max.	42,29	42,52	42,55	42,75
	min.	42,16	42,39	42,42	42,62
R	min.	38,89	38,89	38,89	38,89
S	max.	7,14	7,14	7,14	7,14
	min.	6,35	6,35	6,35	6,35
T		15°	15°	15°	15°
V		30°	30°	30°	30°
X	max.	47,75	59,69	75,44	95,76
	min.	47,50	59,44	75,18	95,38
Y	max.	27,10	36,53	47,75	63,63
	min.	26,85	36,27	47,50	63,37

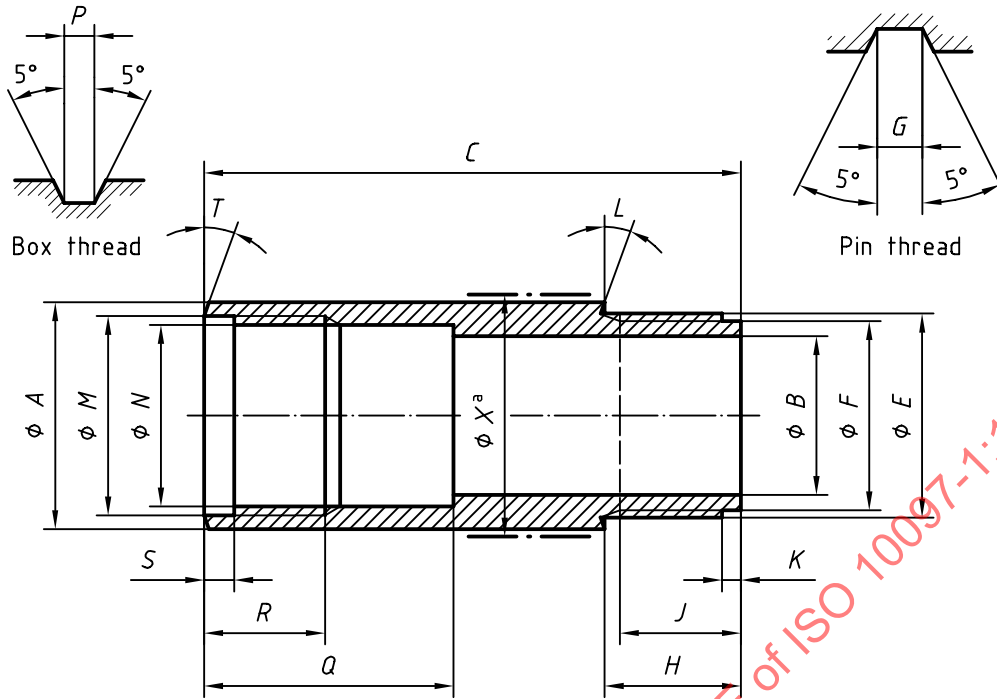

a Set o.d.

Figure 3 — Wireline reaming shell

Table 4 — Wireline reaming shell (see Figure 3)

Dimension		WLA	WLB	WLN	WLH
A	max.	46,66	57,96	73,91	94,31
	min.	46,56	57,86	73,81	94,21
B	max.	36,51	46,04	60,33	77,79
	min.	36,36	45,86	60,12	77,53
C	max.	162,32	159,15	171,85	182,96
	min.	161,53	158,35	171,05	182,17
E	max.	41,96	52,30	67,39	85,62
	min.	41,91	52,25	67,34	85,55
F	max.	40,44	50,72	65,86	84,05
	min.	40,39	50,67	65,81	83,97
Thread pitch		6,35	6,35	6,35	6,35
G	max.	3,20	3,20	3,20	3,20
	min.	3,12	3,12	3,12	3,12
H	max.	41,28	41,38	41,28	41,20
	min.	41,15	41,25	41,15	41,07
J	min.	38,89	38,89	38,89	38,89
K	max.	7,14	7,14	7,14	7,14
	min.	6,35	6,35	6,35	6,35
L		15°	15°	15°	15°
M	max.	42,09	52,43	67,51	85,78
	min.	42,04	52,37	67,46	85,70
N	max.	40,59	50,85	65,99	84,20
	min.	40,51	50,80	65,94	84,12
Thread pitch		6,35	6,35	6,35	6,35
P	max.	3,20	3,20	3,20	3,20
	min.	3,12	3,12	3,12	3,12
Q	max.	61,01	61,32	67,69	74,04
	min.	60,88	61,19	67,56	73,91
R	min.	38,89	38,89	38,89	38,89
S	max.	7,14	7,14	7,14	7,14
	min.	6,35	6,35	6,35	6,35
T		15°	15°	15°	15°
X	max.	48,13	60,07	75,82	96,27
	min.	47,88	59,82	75,57	95,89

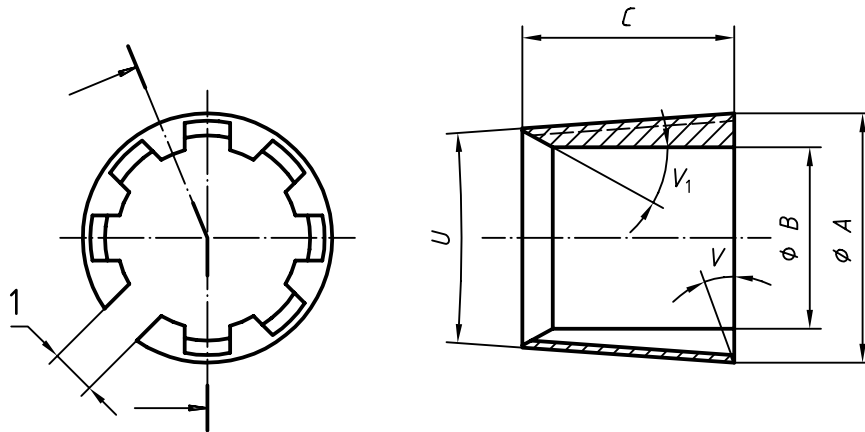
**Key**

1 Gap

Figure 4 — Wireline core lifter**Table 5 — Wireline core lifter (see Figure 4)**

Dimension		WLA	WLB	WLN	WLH
A	max.	30,23	40,23	52,04	68,94
	min.	30,18	40,18	51,99	68,88
B	max.	26,59	36,02	47,12	62,87
	min.	26,54	35,97	47,07	62,81
C	max.	22,62	25,80	28,97	38,50
	min.	21,83	25,00	28,18	37,70
U	max.	5° to 15'	5° to 15'	5° to 15'	5° to 15'
	min.	4° to 45'	4° to 45'	4° to 45'	4° to 45'
V		0°	0°	0°	0°
V ₁		30°	30°	30°	30°

STANDARDSISO.COM :: Click to view the full PDF of ISO 10097-1:1999

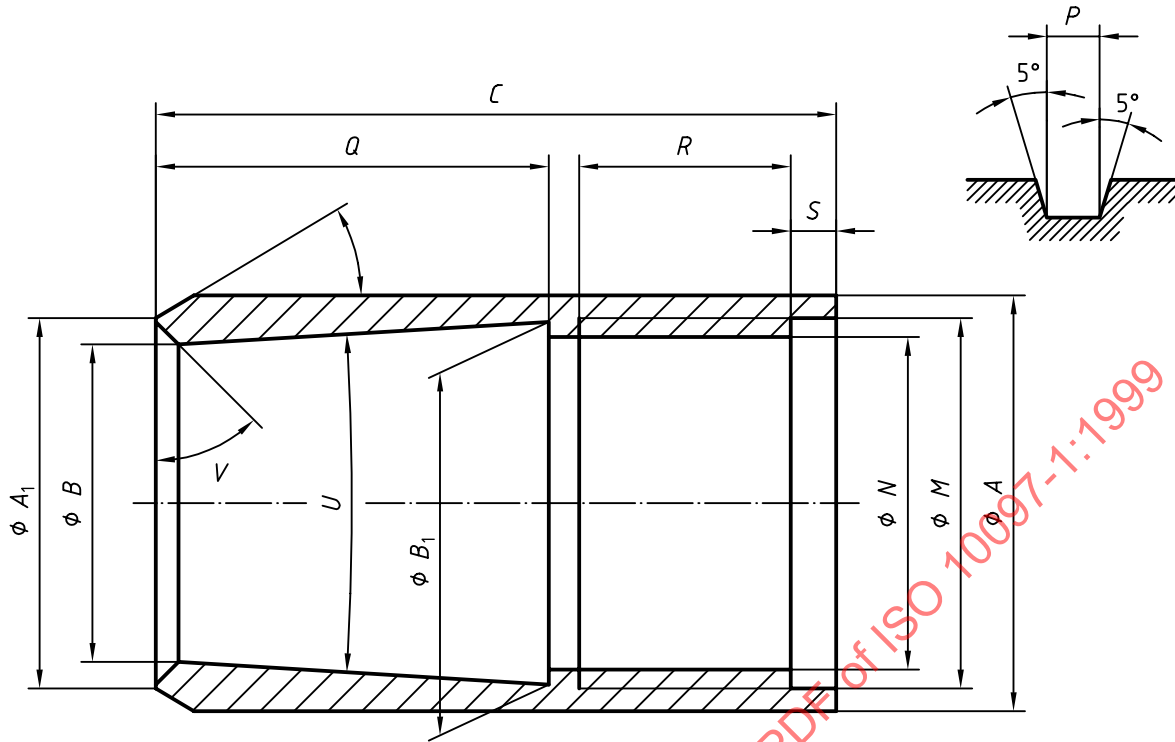

Figure 5 — Wireline core lifter case

Table 6 — Wireline core lifter case (see Figure 5)

Dimension		WLA	WLB	WLN	WLH
A	max.	32,94	43,00	55,93	73,23
	min.	32,89	42,95	55,88	73,18
A ₁	max.	30,68	40,41	52,73	67,99
	min.	30,63	40,35	52,68	67,94
B	max.	28,30	38,02	49,56	65,61
	min.	28,24	37,97	49,50	65,56
B ₁	max.	31,09	41,43	53,21	70,38
	min.	31,01	41,33	53,14	70,31
C	max.	63,90	70,25	75,01	89,30
	min.	63,10	69,45	74,22	88,50
M	max.	31,32	41,10	53,47	70,69
	min.	31,27	41,05	53,42	70,64
N	max.	30,18	39,93	52,20	69,29
	min.	30,12	39,88	52,15	69,24
Thread pitch		3,175	3,175	3,175	3,175
P	max.	1,63	1,63	1,63	1,63
	min.	1,55	1,55	1,55	1,55
Q	max.	40,08	44,85	51,59	67,07
	min.	39,29	44,05	50,80	66,28
R	min.	20,64	20,64	20,64	20,64
S	max.	3,97	3,97	3,97	3,97
	min.	3,18	3,18	3,18	3,18
T		30°	30°	30°	30°
U	max.	5° to 15'	5° to 15'	5° to 15'	5° to 15'
	min.	4° to 45'	4° to 45'	4° to 45'	4° to 45'
V		45°	45°	45°	45°

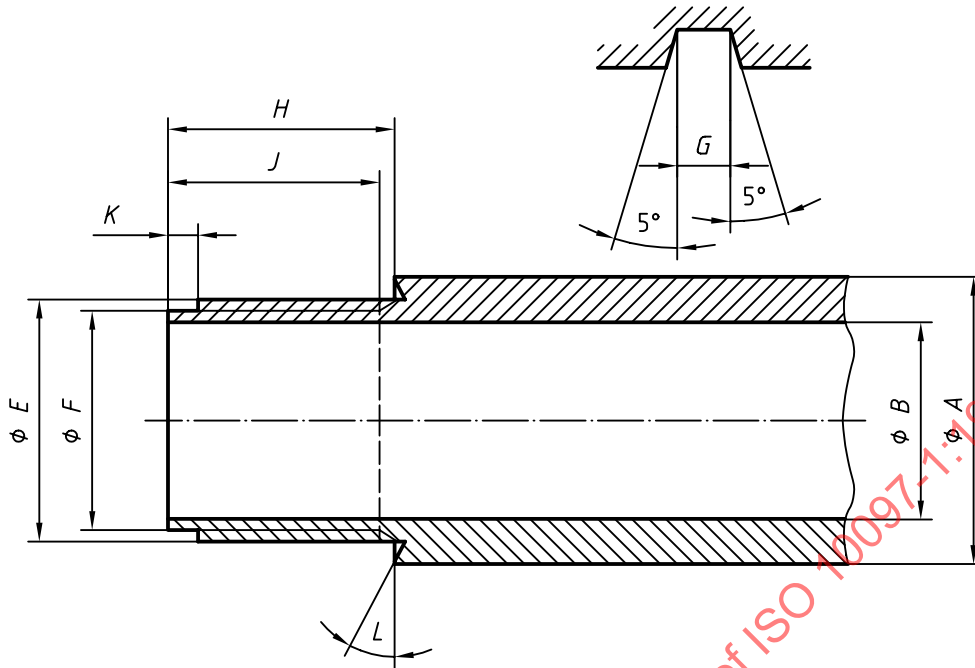

Figure 6 — Wireline core barrel outer tube (lower end)

Table 7 — Wireline outer tube (lower end) (see Figure 6)

Dimension		WLA	WLB	WLN	WLH
A	max.	46,19	57,33	73,23	92,33
	min.	46,04	57,15	73,03	92,08
B	max.	36,51	46,04	60,53	77,79
	min.	36,36	45,86	60,33	77,53
E	max.	41,96	52,30	67,39	85,62
	min.	41,91	52,25	67,34	85,55
F	max.	40,44	50,72	65,86	84,05
	min.	40,39	50,67	65,81	83,97
Thread pitch		6,35	6,35	6,35	6,35
G	max.	3,20	3,20	3,20	3,20
	min.	3,12	3,12	3,12	3,12
H	max.	41,28	41,48	41,38	41,28
	min.	41,15	41,35	41,25	41,15
J	min.	38,89	38,89	38,89	38,89
K	max.	7,14	7,14	7,14	7,14
	min.	6,35	6,35	6,35	6,35
L	min.	15°	15°	15°	15°

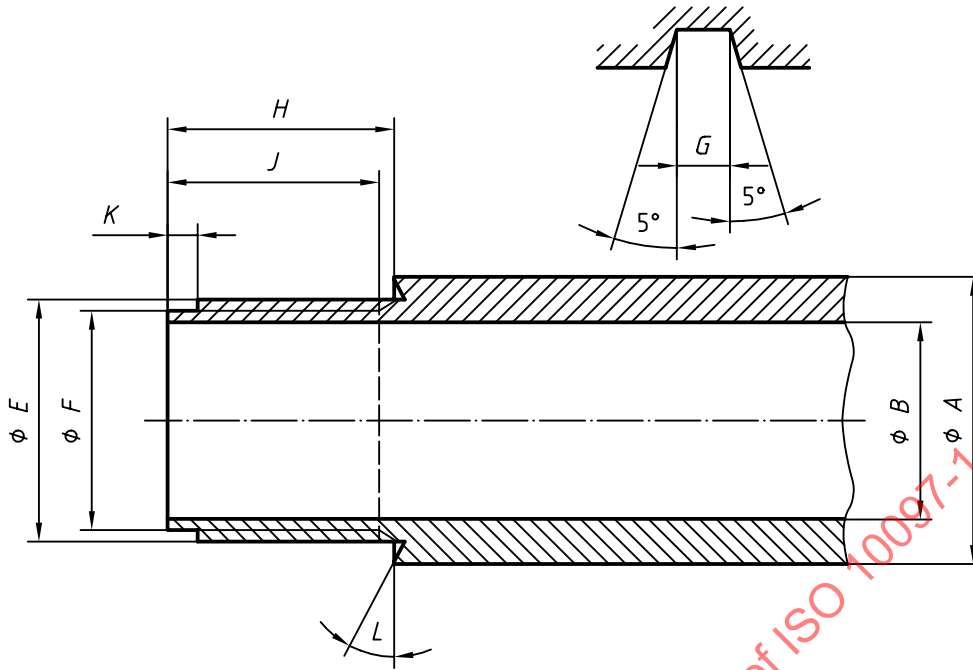

Figure 7 — Wireline core barrel inner tube (lower end)

Table 8 — Wireline core barrel inner tube, lower end

Dimension		WLA	WLB	WLN	WLH
A	max.	32,67	42,99	55,74	73,23
	min.	32,54	42,86	55,56	73,03
B	max.	28,58	38,10	50,01	66,93
	min.	28,45	37,97	49,83	66,73
E	max.	31,24	40,97	53,34	70,56
	min.	31,19	40,92	53,29	70,51
F	max.	30,07	39,80	52,07	69,16
	min.	30,02	39,75	52,02	69,11
Thread pitch		3,175	3,175	3,175	3,175
G	max.	1,63	1,63	1,63	1,63
	min.	1,55	1,55	1,55	1,55
H	max.	22,10	22,10	22,10	22,10
	min.	21,97	21,97	21,97	21,97
J	min.	20,64	20,64	20,64	20,64
K	max.	3,97	3,97	3,97	3,97
	min.	3,18	3,18	3,18	3,18
L	min.	0°	0°	0°	0°